

TOWN OF WEST SENECA



ENGINEERING DEPARTMENT

TOWN SUPERVISOR
SHEILA M. MEEGAN
TOWN COUNCIL
EUGENE P. HART
WILLIAM P. HANLEY JR.

June 4, 2018

Honorable Town Board
Town of West Seneca

Honorable Board Members,

Please authorize the supervisor to execute the attached Change Order #1 to MKS Plumbing in the ADD amount of \$2,006.00 for Plumbing construction associated with sink modifications, chase modifications and wall relocations associated with the West Seneca Community Center and Library.

Feel free to contact me if you have any questions.

Very truly yours,

A handwritten signature in black ink, appearing to read "S. R. Tanner".

Steven R. Tanner, P.E.

cc. Files: TB
Project

Change Order No. 1

Date of Issuance: June 4, 2018 Effective Date: June 4, 2018

Project: Community Center and Library	Owner: Town of West Seneca	Owner's Contract No.: N/A
Contract: Community Center and Library		Date of Contract: 12/5/2016
Contractor: MKS Plumbing, Inc.		Engineer's Project No.: 13727.01

The Contract Documents are modified as follows upon execution of this Change Order:

Description: Change in sinks, Wall relocations and chase modifications

Total Change Order Amount **\$2,006.00**

Attachments (list documents supporting change): Contractors letter

CHANGE IN CONTRACT PRICE:

CHANGE IN CONTRACT TIMES:

Original Contract Price:

\$ 444,000.00

Original Contract Times: Working Calendar days

Substantial completion date: May 1, 2018

Ready for final payment (date): June 1, 2018

Increase from previously approved Change Orders

\$ 0

Increase from previously approved Change Orders:

Substantial completion (date): No change

Ready for final payment (date): No change

Contract Price prior to this Change Order:

\$ 444,000.00

Increase of this Change Order

\$ 2,006.00

Contract Price incorporating this Change Order:

\$ 446,006.00

RECOMMENDED:

By: _____

Engineer (Authorized Signature)

Date: _____

ACCEPTED:

By: _____

Owner (Authorized Signature)

Date: _____

ACCEPTED:

By: _____

Contractor (Authorized)

Date: _____



M/623 @ C.O. File

19 RANSIER DRIVE
WEST SENECA, NY 14224

716-675-5771 PHONE
716-675-0441 FAX

ADDITIONAL WORK COST BREAKDOWN

TO: CLARK PATTERSON LEE
26 MISSISSIPPI ST., SUITE 300
BUFFALO, NY 14202

DATE: 1/12/2018
PROJECT: WEST SENECA COMMUNITY
CENTER/LIBRARY

ATTN: STEVE TANNER

MKS #6 DESCRIPTION OF WORK

RETURN (7) EXISTING SK-1 SINKS THAT WERE APPROVED FOR 18 1/2" X 18 1/2" IN SIZE
FURNISH (7) NEW SK-1 SINKS THAT ARE TO BE 16 1/2" X 16 1/2"

LABOR RATE	QTY	PER	RATE		
PLUMBER FOREMAN		HR.	\$ 81.95	\$	-
PLUMBER JOURNEYMAN		HR.	\$ 75.80	\$	-
				\$	-
				\$	-
				\$	-
				\$	-
				\$	-
TOTAL LABOR				\$	-

MATERIAL	QTY	PER	PRICE		
CREDIT BACK ORIGINAL SK-1 SINKS	7.00	EA.	\$ (244.00)	\$	-
ADD FREIGHT TO SEND BACK	1.00	LS	\$ 80.00	\$	(1,708.00)
				\$	80.00
ADD FOR NEW SK-1 SINK 16 1/2" X 16 1/2"	7.00	EA.	\$ 261.21	\$	-
				\$	1,828.47
				\$	-
				\$	-
				\$	-
				\$	-
				\$	-
				\$	-
				\$	-
				\$	-
				\$	-
				\$	-
				\$	-
				\$	-
				\$	-
				\$	-
				\$	-
				\$	-
				\$	-
TOTAL MATERIALS				\$	200.47

SUBCONTRACTORS			
TOTAL SUBS			\$ -

EQUIPMENT & TOOL	QTY	PER	RATE		
				\$	-
				\$	-
TOTAL EQUIPMENT				\$	-

OVERHEAD AND PROFIT			
LABOR	15%		\$ -
MATERIAL	15%		\$ -
SUBCONTRACTOR	5%		\$ 30.07
EQUIPMENT & TOOL	15%		\$ -
			\$ -
			\$ 30.07

ADDITIONAL BOND COST	\$	-
GRAND TOTAL	\$	231.00

Joseph A. Marchitte

 JOSEPH A. MARCHITTE, PRESIDENT

P R I C E Q U O T A T I O N
 VP Supply Corp - Buffalo
 2240 Harlem Road
 Cheektowaga, NY 14225
 716-895-2800

Page : 1

Printed At : 09:13:56 12 JAN 2018

Quote Date 01/12/18	Quote No. 2274471	Quote Expiration Date 02/11/18	Writer DR	Slsm 4	WH 4	
------------------------	----------------------	-----------------------------------	--------------	-----------	---------	--

Quoted To:M.K.S.-0183

Ship To:M.K.S.-0183

MKS PLUMBING CORP
 19 RANSIER DR
 BUFFALO, NY 14224-2259

M1623 WEST SENECA COMM CTR
 COMMUNITY CTR AND LIBRARY
 1250 UNION RD
 WEST SENECA NY 14224
 FOR THE TOWN OF W SENECA

M1623							
Ln	Order Quant	EDP Code / Description	Net Price	UM	Ext Price		
1		RESTOCK ON THE 7 SINKS HERE					
2		ALREADY-\$244.00 PLUS FREIGHT					
3		BACK OF 80.00					
4							
5	7	ELUHAD141855PD 18GA SNGL BWL UM W/PERFECTDR	261.209	EA	1828.46		

Net Amount	\$1,828.46
Tax	\$0.00
Quotation Total	\$1,828.46

PRODUCT SPECIFICATIONS

Elkay Lustertone Stainless Steel 16-1/2" x 16-1/2" x 5-3/8", Single Bowl Undermount ADA Sink with Perfect Drain. Sink is manufactured from 18 gauge 304 Stainless Steel with a Lustertone finish, Rear Center drain placement, and Bottom only pads.

Installation Type:	Undermount
Material:	304 Stainless Steel
Special Features:	Perfect Drain
Finish:	Lustertone
Gauge:	18
Sound Deadening:	Bottom only pads
Number of Bowls:	1
Sink Dimensions:	16-1/2" x 16-1/2" x 5-3/8"
Bowl 1 Dimensions:	14" x 14" x 5-3/8"
Drain Size:	3-1/2" (89mm)
Drain Location:	Rear Center
Minimum Cabinet Size:	21"
Template Included:	Yes
Cutout Template #:	1000001265

Template is available for download at elkay.com



This sink is compliant to ADA and ANSI/ICC A117.1 accessibility requirements when installed according to the requirements outlined in these standards.

Perfect Drain: Seamlessly welded stainless steel collar eliminates the gap between a traditional drain and the sink for a sanitary and gap free installation. An InSinkErator® garbage disposer can be installed on either sink bowl for user convenience. **Patent Pending**

Installation Profile:

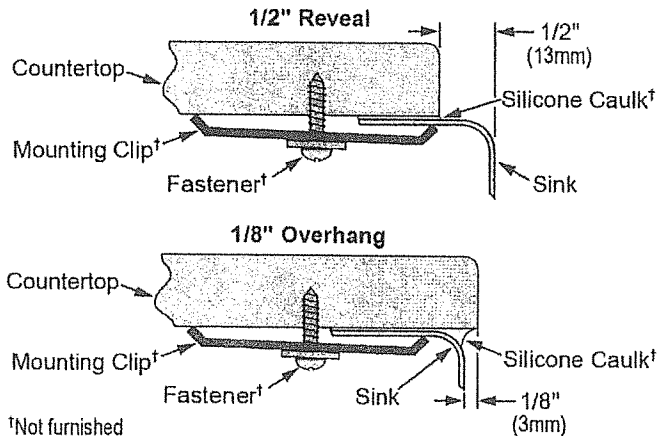

†Not furnished

Designed to affix to the underside of any solid surface countertop.

PART: _____ QTY: _____
 PROJECT: _____
 CONTACT: _____
 DATE: _____
 NOTES: _____
 APPROVAL: _____

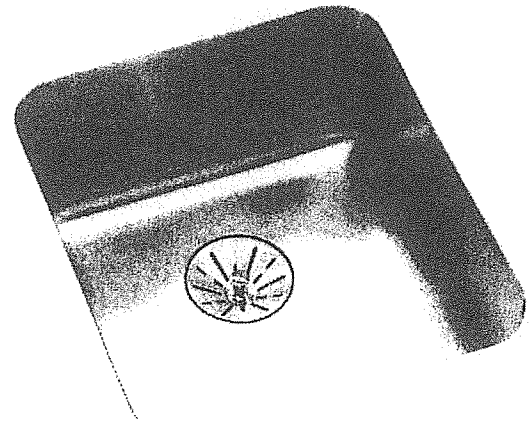

Included with Product: One LKPD1 Perfect Drain and Strainer

AMERICAN PRIDE. A LIFETIME TRADITION.

Like your family, the Elkay family has values and traditions that endure. For almost a century, Elkay has been a family-owned and operated company, providing thousands of jobs that support our families and communities.



Sinks are listed by IAPMO® as meeting the applicable requirements of the Uniform Plumbing Code®, International Plumbing Code®, and National Plumbing Code of Canada.

Product Compliance: ADA & ICC A117.1
 ASME A112.19.3/CSA B45.4
 BUY AMERICAN ACT
Accessory: ASME A112.18.2/CSA B125.2

[Clean and Care Manual \(PDF\)](#)

[Installation Instructions \(PDF\) - 1000002045](#)

[Installation Instructions \(PDF\) - 74180289 Disposer](#)

[Installation Instructions \(PDF\) - 74180340-USA Drain](#)

[Warranty \(PDF\)](#)

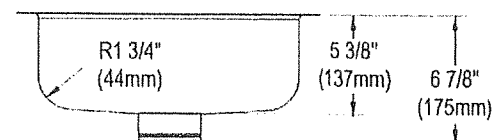
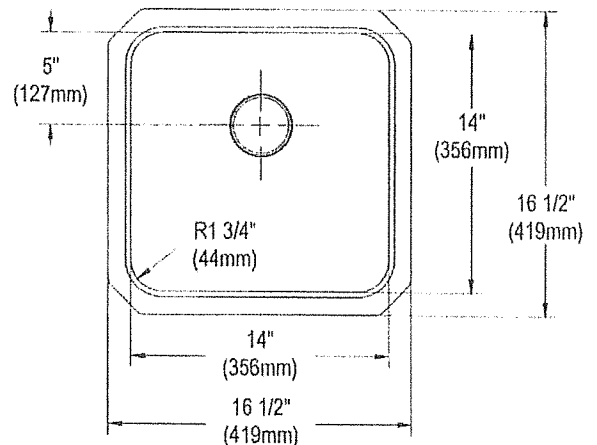

In keeping with our policy of continuing product improvement, Elkay reserves the right to change product specifications without notice. Please visit elkay.com for the most current version of Elkay product specification sheets. This specification describes an Elkay product with design, quality, and functional benefits to the user. When making a comparison of other producers' offerings, be certain these features are not overlooked.

ELKAY[®]

SPECIFICATIONS

Elkay Lustertone Stainless Steel 16-1/2" x 16-1/2" x 5-3/8" Single Bowl Undermount ADA Sink with Perfect Drain Model(s) ELUHAD141455PD

OPTIONAL ACCESSORIES

Cutting Board:	CB1613
Drain:	LKPDVR18B, LKPDAD18B, LKDS99
Faucet:	LKGT1042, LKGT2042, LKLFGT1042, LKLFGT2042
Rinsing Basket:	LKWRB1414SS, LKWUCSS
Sinkmate:	LKSMHSL
Soap Dispenser:	LKGT1054

in sink erator[®]

Elkay[®] Perfect Drain[™] sinks are designed and approved for compatible disposers manufactured by InSinkErator[®] utilizing the Quick Lock[®] mounting configuration. Use of non-approved disposers may void Elkay warranty.

InSinkErator, Quick Lock and the mounting collar configuration are trademarks of Emerson Electric Co.

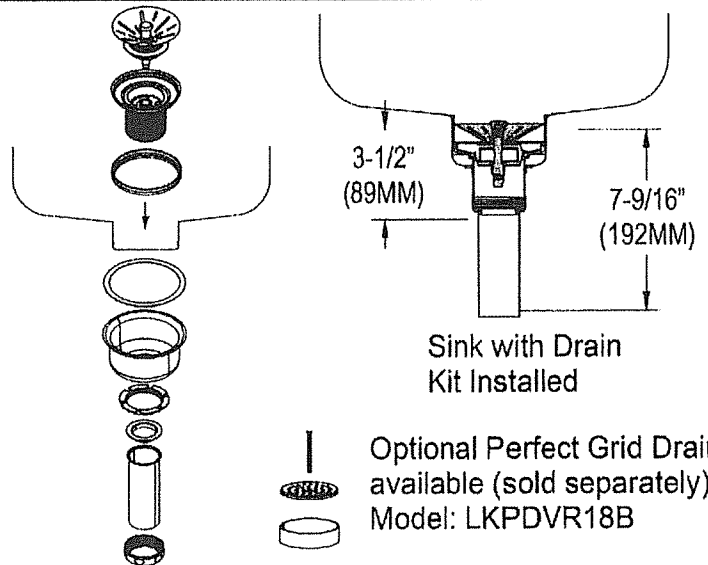

Optional Perfect Grid Drain
available (sold separately)
Model: LKPDVR18B

In keeping with our policy of continuing product improvement, Elkay reserves the right to change product specifications without notice. Please visit elkay.com for the most current version of Elkay product specification sheets. This specification describes an Elkay product with design, quality, and functional benefits to the user. When making a comparison of other producers' offerings, be certain these features are not overlooked.



19 RANSIER DRIVE
WEST SENECA, NY 14224

716-675-5771 PHONE
716-675-0441 FAX

ADDITIONAL WORK COST BREAKDOWN

TO: CLARK PATTERSON LEE
26 MISSISSIPPI ST., SUITE 300
BUFFALO, NY 14202

DATE: 1/26/2018
PROJECT: WEST SENECA COMMUNITY
CENTER/LIBRARY

ATTN: STEVE TANNER

MKS#8 DESCRIPTION OF WORK

12/21/2017 RM 152 KICTHEN SINK UNDERSLAB 2" CAST IRON WASTE LINE NEEDED TO BE MOVED DUE TO WALL DISCREPANCY BETWEEN IB16 AND IB50. HAD TO SAWCUT AND JACK HAMMER THE FLOOR ALSO.

AEWR# 22855

LABOR RATE

	QTY	PER	RATE	
PLUMBER FOREMAN	4.00	HR.	\$ 81.95	\$ 327.80
PLUMBER JOURNEYMAN	0.00	HR.	\$ 75.80	-
TOTAL LABOR				\$ 327.80

MATERIAL

	QTY	PER	PRICE	
2" SVSH PIPING	1.00	LGTH	\$ 62.85	\$ 62.85
2" SV GASKET	1.00	EA	\$ 3.80	\$ 3.80
TOTAL MATERIALS				\$ 66.65

SUBCONTRACTORS

TOTAL SUBS				\$ -
-------------------	--	--	--	------

EQUIPMENT & TOOL

	QTY	PER	RATE	
TOTAL EQUIPMENT				\$ -

OVERHEAD AND PROFIT

LABOR	15%		\$ 49.17
MATERIAL	15%		\$ 10.00
SUBCONTRACTOR	5%		\$ -
EQUIPMENT & TOOL	15%		\$ -
			\$ 59.17

ADDITIONAL BOND COST

GRAND TOTAL	\$ 454.00
--------------------	-----------

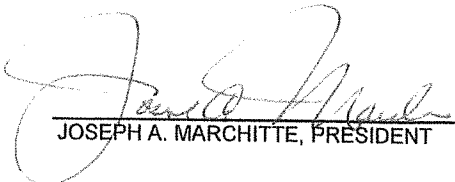
JOSEPH A. MARCHITTE, PRESIDENT



22855

19 Ransier Drive, West Seneca, NY 14224
 (716) 675-5771 Phone (716) 675-0441 Fax

AUTHORIZED EXTRA WORK REPORT

Job Name: W.S. Comm. ER & Library
 Address: _____
 Customer Contact: _____
 Address: _____

Date: 12-21-17
 Job #: M. 1623

DESCRIPTION OF WORK:
Do to wall discrepancy in Room 152 between
IB 16 and IB 50 of 20", the 2" CZ
waste line for the Kitchen Sink under slab had to
be moved westward in the room.

Floor needed to be ~~br~~ cut & Jack hammered up

LABOR				TOOLS & EQUIPMENT			
TRADE	EMPLOYEE	HOURS WORKED			DESCRIPTION	EQUIP. #	USED
		REG.	1/2	2			
F	Sam Stark	4			SERVICE VAN		
					PICK UP		
					SEWER CAMERA		
					SEWER MACHINE		
					DRAIN MACHINE		
					SEWER JETTER		
					Target Site		1 hr.
					60 lb Jack Hammer		2 hrs.

MATERIALS					
QTY	DESCRIPTION	QTY	DESCRIPTION	SUPPLIER	TICKET#
1	5' 2" Single Hub SV Pipe				
1	2" SV Quick Tight gasket				

SUBCONTRACTOR	HOURS WORKED			Job Completed?	yes	no
	REG.	1/2	2		<input type="checkbox"/>	<input type="checkbox"/>

Authorized Signature: _____



19 RANSIER DRIVE
WEST SENECA, NY 14224

716-675-5771 PHONE
716-675-0441 FAX

ADDITIONAL WORK COST BREAKDOWN

TO: CLARK PATTERSON LEE
26 MISSISSIPPI ST., SUITE 300
BUFFALO, NY 14202

DATE: 1/26/2018
PROJECT: WEST SENECA COMMUNITY
CENTER/LIBRARY

ATTN: STEVE TANNER

MKS#9 DESCRIPTION OF WORK

1/9/18 AFTER COMPLETION OF IN WALL ROUGH IN OF WASTE, VENT AND WATER ON THE NORTH WALL OF RM 119, RFI 119 WAS GENERATED. THE ANSWER WAS TO MOVE THE PLUMBING 12" EAST TO ACCOMMODATE MANOFOLD CHASE.

AEWR# 22857

LABOR RATE

	QTY	PER	RATE	
PLUMBER FOREMAN	8.00	HR.	\$ 81.95	\$ 655.60
PLUMBER JOURNEYMAN	0.00	HR.	\$ 75.80	-
				-
TOTAL LABOR				\$ 655.60

MATERIAL

	QTY	PER	PRICE	
2" DWV COPPER 45	2.00	EA	\$ 7.55	\$ 15.10
2 X 1 1/2" DWV TY	1.00	EA	\$ 14.29	\$ 14.29
1 1/2" DWV WYE	1.00	EA	\$ 27.43	\$ 27.43
1 1/2" DWV ST. 45	1.00	EA	\$ 4.59	\$ 4.59
1 1/2" DWV 90	2.00	EA	\$ 6.46	\$ 12.92
1 1/2" DWV CPLG	1.00	EA	\$ 2.51	\$ 2.51
1/2" C X C 90	12.00	EA	\$ 0.46	\$ 5.52
1/2" C X C CPLG	2.00	EA	\$ 0.45	\$ 0.90
1/2" TYPE "L" COPPER	10.00	FT	\$ 1.46	\$ 14.60
1 1/2" DWV COPPER PIPE	5.00	FT	\$ 4.70	\$ 23.50
				-
				-
				-
				-
				-
				-
				-
				-
				-
				-
				-
TOTAL MATERIALS				\$ 121.36

SUBCONTRACTORS

TOTAL SUBS				\$ -

EQUIPMENT & TOOL

	QTY	PER	RATE	
TOTAL EQUIPMENT				\$ -

OVERHEAD AND PROFIT

LABOR	15%		\$	98.34
MATERIAL	15%		\$	18.20
SUBCONTRACTOR	5%		\$	-
EQUIPMENT & TOOL	15%		\$	-
				\$ 116.54

ADDITIONAL BOND COST

GRAND TOTAL \$ 894.00

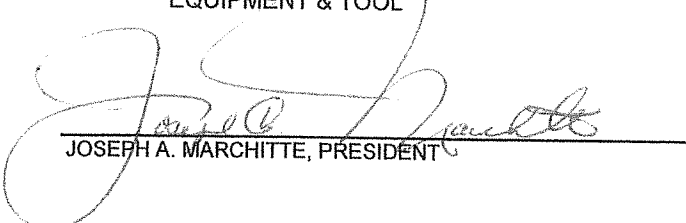
JOSEPH A. MARCHITTE, PRESIDENT



22857

19 Ransier Drive, West Seneca, NY 14224
 (716) 675-5771 Phone (716) 675-0441 Fax

AUTHORIZED EXTRA WORK REPORT

Job Name: W.S Comm CTR & Library
 Address: _____
 Customer Contact: _____
 Address: _____

Date: 1-9-18
 Job #: M-1623

DESCRIPTION OF WORK:
After completion of mwall rough of Waste, Vent, & Water on the North wall of the Makers Space Rm 119, RFI 119 was generated. The Answer was to move the Plumbing 12" east to accommodate Manifold chase.

LABOR

TRADE	EMPLOYEE	HOURS WORKED		
		REG.	1 1/2	2
F	Sam Stirk	8		

TOOLS & EQUIPMENT

DESCRIPTION	EQUIP. #	USED
SERVICE VAN		
PICK UP		
SEWER CAMERA		
SEWER MACHINE		
DRAIN MACHINE		
SEWER JETTER		

MATERIALS

QTY	DESCRIPTION	QTY	DESCRIPTION	SUPPLIER	TICKET#
2	2" DWV 45° Copper	12	1/2 Copper 90°		
1	2x 1 1/2 Tee	2	1/2 " Couplings		
1	1 1/2 DWV wye	10'	1/2 L Copper		
1	1 1/2 DWV 57 45°	5'	1 1/2 DWV "		
2	1 1/2 DWV 90°				
1	1 1/2 DWV Coupling				

SUBCONTRACTOR	HOURS WORKED		
	REG.	1 1/2	2

Job Completed? yes no

Authorized Signature: _____



ALLOWANCE DISBURSEMENT AUTHORIZATION

Owner	X
Architect/Engineer	X
Contractor	X
Field	
Other	
Other	

(PROJECT NAME)

Allowance Disbursement No. 2 Initiation Date: January 4, 2017
Contract For: Mechanical
Disbursements: IB-50 and rerouting of gutter
To Contractor: MKS Plumbing Corp.
19 Ransier Drive, West Seneca, NY 14224
Contract Date: December 5th, 2017

Not valid until signed by Owner, Architect/Engineer, [Construction Manager] and Contractor.

The Original Contract Allowance	\$50,000.00	
Net Allowance Disbursements previously authorized	\$31,022.00	
Charges to Contract Allowance as a result of this authorization	\$19,405.00	
	\$-427.00	(your first change order will cover this when issued)
Current Contract Allowance Balance including this authorization		

Owner: Town of West Seneca Supervisor Sheila Meegan
<Owner's Name>
Architect/Engineer: Clark Patterson Lee – Steven R. Tanner
Clark Patterson Lee
Contractor: MKS Plumbing – Joseph Marchitte

